

GENERAL DESCRIPTION AND ACCESSORIES

Pneumatic distance- knocker QJ from singold



- World's most powerful distance knockers
- Greatest possible impact effect
- Reliably remove product residues and caking in rotating drums
- Ideal for rotary kilns and drum dryers and for hot surfaces in general
- Also suitable for filter cup knocking stations, centrifuge drum cleaning stations and many other applications

1 USAGE

The Distance-Knocker QJ is universally applicable wherever successful cleaning can be achieved by a hammer blow however, directly mounting a conventional knocker is impossible due to movement or temperature. Therefore, the QJ is the ideal choice for filling and emptying stations with changing containers, slowly rotating drums, and hot surfaces.

The QJ Pneumatic distance knocker is used, for example, in rotary kilns, drum drying systems, filter cup knocking stations, centrifuge drum cleaning stations and many other applications.

2 CONSTRUCTION AND FUNCTIONING

The Pneumatic Knocker achieves a very high impact energy by spontaneously released stored compressed air energy. The Figure on the right shows the structure of the Distance-Knocker QJ.

The percussion piston (3) is a permanent magnet and in basic position this piston adheres to the anchor plate (2) until the compressed air supplied through the lid (1) overcomes the magnetic holding force. The percussion piston (3) is released from the anchor plate (2) and highly accelerated by the stored compressed air.

The piston strikes with high speed on the piston rod (5).

The piston rod is accelerated spontaneously and transfers the impulse energy to the element to be knocked (rotary drum wall etc.), bounces back immediately and is thereby moved back onto the percussion piston (3).

When the Distance-Knocker QJ is vented, the upper spring (4) pushes the percussion piston (3) back against the anchor plate (2) and the lower spring (6) pushes the piston rod (5) back into its starting position.

The speed of the piston rod (5) is so great that the entire process is barely visible to the human eye.

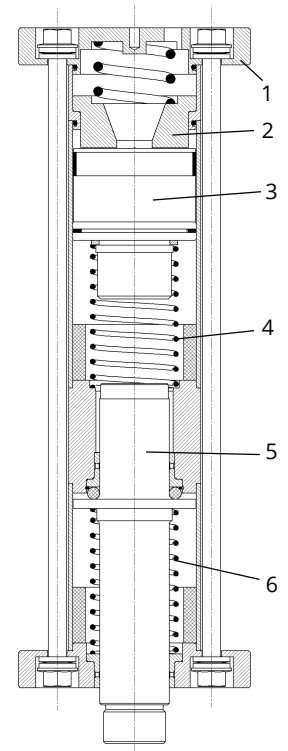

3 SELECTION KNOCKER SIZE

The selection of the size of the Pneumatic Distance-Knocker QJ for your application should always be made in consultation with singold.

Important design parameters are, for example, the diameter of the rotating drum, the thickness or sheet thickness of the drum wall, the peripheral speed in m / s of the drum and the temperature of the drums surface.

4 CONTROL AND ASSEMBLY REQUIREMENTS

The Distance-Knocker QJ is controlled by an electrical control with a solenoid valve. It requires a working time (pressure applied) for the function and a pause time (vented) for returning to the starting position.

You can find out more about the cycle times in our assembly, operating and maintenance instructions.

Required accessories for automatic operation, see point 6.

The Distance-Knocker QJ has to be securely installed to a greater mass (e.g. machine-construction, U-steel filled with concrete) to cover the recoil.

5 RANGE OF APPLICATION

Not approved in ATEX areas. It is intended for use in industrial interiors. Device is not splash-proof.

For outdoor use, in the presence of humidity and extreme dirt and dust, we recommend the use of the Sound Insulation Hood (QJSH), which is available as an accessory. Versions in stainless steel are available too.

Furthermore, galvanization-free, and non-ferrous metal-free versions with components made of stainless steel are available.

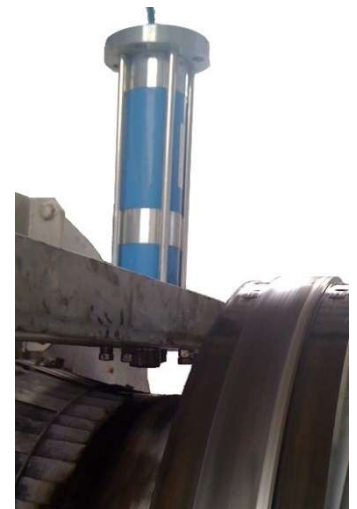

6 NECESSARY ACCESSORIES FOR THE INSTALLATION AND OPERATION OF THE DISTANCE-KNOCKER QJ

Automatic operation
A machine frame that is as stiff as possible for mounting the distance knocker (e.g. machine frame, steel profiles poured with concrete)
Compressed air maintenance unit with oiler and pressure reducer
Pneumatic connection fittings and pneumatic hoses
Electrical control for the timing of compressed air and electro-pneumatic 3/2 directional solenoid valve

More about available accessories - see point 12.

7 TECHNICAL DATA PNEUMATIC DISTANCE-KNOCKER TYPE QJ:

Type	Dimensions in mm																	Magnetic holding force N	Dynam. Energy Nm	weight piston-rod kg	Total weight kg	
	B	C	D	E	F	G	H	H1	H2	H3	K	L	M (with thread)	M	P	R	S					SW
QJ 63	22	14	120	35	50	7	345	30	10	3	10	95	M30x1,5	30	20	1/4"	15	30	640	25,6	1,4	9,2
QJ 80	24	18	150	45	60	9	425	35	12	4	12	120	M40x1,5	40	25	1/4"	15	41	1160	63,8	2,9	17,4
QJ100	31	22	190	64	80	11	515	40	15	5	20	150	M55x2,0	55	35	3/8"	20	55	1620	92,3	6,8	33,5
QJ125	45	26	240	80	100	12	670	45	20	9	20	190	M70x2,0	70	40	1/2"	25	70	2560	204,8	14,5	70,1

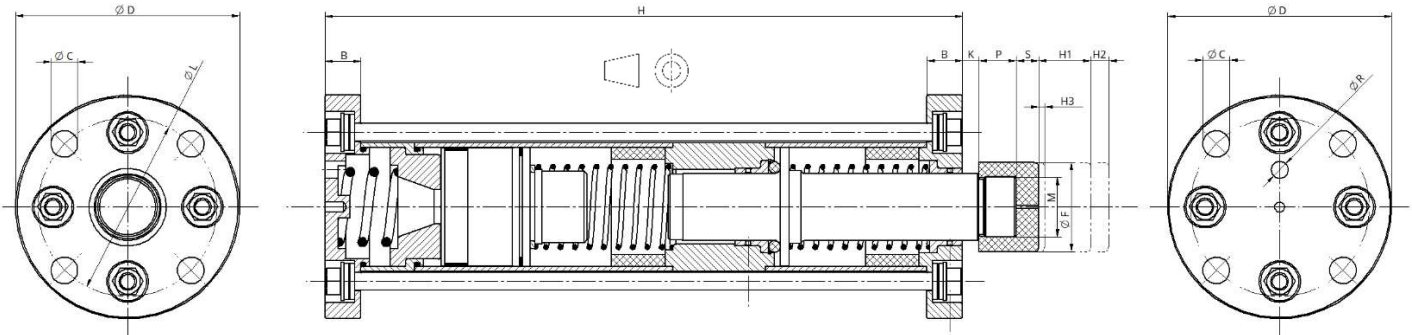

8 INSTALLATION DIMENSIONS

Distance (A) piston rod end to the point of impact

	a_{min} (mm)	a_{max} (mm)	with Vulcollan buffer (mm)
	H3+H3	H1-H3	+ S
QJ 63	6	27	+ 15
QJ 80	8	31	+ 15
QJ100	10	35	+ 20
QJ125	18	36	+ 25

Distance (a) foot flange to the point of impact

	a_{min} (mm)	a_{max} (mm)	with Vulcollan buffer (mm)
	H3+H3+P+K	H1-H3+P+K	+ S
QJ 63	36	57	+15
QJ 80	45	68	+15
QJ100	65	90	+ 20
QJ125	73	96	+ 25

9 VARIANTS

Pneumatic Distance-Knocker QJ - Variants			
			Temp. Accessories
Pneumatic Distance-Knocker QJ	QJ__A	Piston rod without thread	0- 60 °C
	QJ__B	Piston rod with external thread	
	QJ__C	Piston rod with internal thread and mount for special Vulcollan buffer	
	QJ__D	Piston rod with internal thread	
	QJ__E	Combination of variants B+D	
	QJ__S4 A/B/C/D/E		

10 AVAILABLE VERSIONS

Pneumatic Distance-Knocker QJ - Versions							
Pneumatic Distance-Knocker QJ	Type	Version	Maximum operating temperature [°C]	Material			
				Lid, bottom plate, intermediate piece	Tubes	Piston Rod	
Pneumatic Distance-Knocker QJ	QJ__A/B	Standard design	60	Galvanized steel	Steel powder-coated on the outside	Stainless steel	
	QJ__A/B - S2	-S	2				80
	QJ__A/B - S4		4				140
	QJ__A/B - T1	-T	1	60	Stainless steel		
	QJ__A/B - T4		4	140			
	QJ__A/B - K1	-K	1	60	Stainless steel		
	QJ__A/B - K4		4	140			

e.g. knocker QJ80A-K4: Distance knocker QJ80 in variant A in stainless steel design for operating temperatures up to 140 °C

We also supply non-galvanized and non-ferrous metal-free versions especially for the metallurgical sector. Upon request, the piston rod can also be delivered in an extended or reinforced version as well as with a shoulder for position detecting using inductive sensor technology.

11 PISTON ROD OPTIONS IN DETAIL

11.1 Extended piston rod

The piston rod is also available in an extended version in which the highest possible knocker distance can be increased for example in the case of hot surfaces.

Type Description	QJ	---	-	-	X	---
Distance-Knocker						
Dimension = Piston Ø						
Piston Rod Type						
A = without thread						
B = with thread						
Special design						
S4 for 140°C						
extended distance						

For Example:
 Distance-Knocker Type QJ100
 Piston Rod without thread
 Special design up to 140°C
 Extended distance 150 mm
 Part Number: **QJ100A-S4X150**

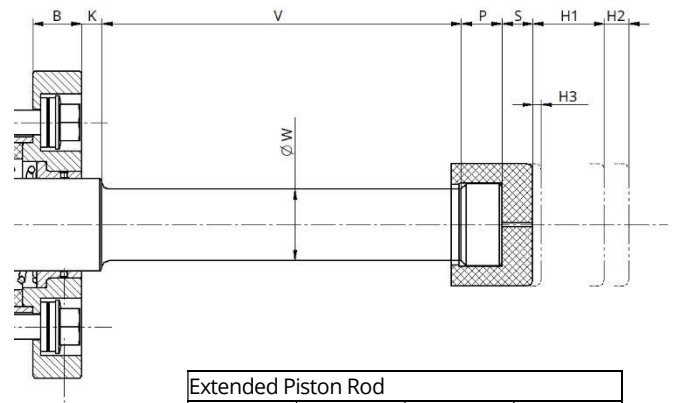

Extended Piston Rod			
Type	V _{max} [mm]	W [mm]	kg
QJ 63	200	26	2,228
QJ 80	170	35	4,163
QJ100	270	50	10,947
QJ125	150	65	16,000

11.2 Piston rod with shoulder for position detection using an inductive sensor

For this purpose, we can deliver the Distance-Knocker QJ also with special piston rods with a shoulder so that this shoulder can be detected with an inductive proximity switch. The position of the shoulder can be freely selected when an order is placed. The picture on the right shows a piston rod that was made for a QJ125A-150 in coordination with a customer.

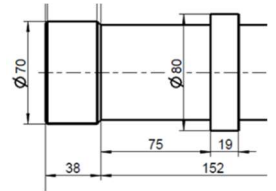

Pneumatic Distance-Knocker QJ – Accessories

12 AVAILABLE ACCESSORIES FOR INSTALLATION AND OPERATION KNOCKER K AND DISTANCE-KNOCKER QJ

12.1 Sound Insulation Hood (QJSH)

to reduce the noise emission of the knocker. See also dimension sheet 100-088. Can also be used as protection against entrainment of the ventilation holes and protection against parts which are loosened if the knocker is damaged.

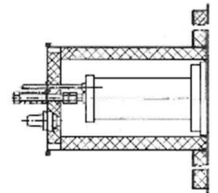

12.2 Pneumatic solenoid valves (MV)

in 24V DC and 230V AC. Special voltages on request. Depending on the type used and the number of knockers available in 1/8", 1/4", 1/2".



12.3 Impulser (TG)

For easy control and adjustment of the pause and working times for the timing of the Pneumatic Knocker. Available in 24V DC and 230V AC. Quick installation and setting into operation of the knocker. Particularly suitable if the optimal setting times are not known yet. Pauses and working times can be changed manually at any time via two potentiometers.



12.4 Maintenance unit (WE)

With pressure reducer and oiler for cleaned and oiled compressed air supply.

